

**Tomfow**<sup>®</sup>



IT'S VERY WELL  
MADE IN TAIWAN

## 主要產品

CNC車床油壓夾盤  
POWER CHUCK FOR CNC LATHE

超高速中空迴轉油壓缸  
HIGH SPEED HOLLOW HYDRAULIC CYLINDER

精密軟爪、硬爪  
HIGH PRECISION HARD JAWS AND SOFT JAWS

精密套筒夾頭  
POWER OPERATED COLLET CHUCK

## 經營理念

永續經營  
Eternal Management

誠信基礎  
Reliable Conception

客戶滿意  
Customer Satisfaction

合理價位  
Reasonable Price

超高品質  
High Quality



# INDEX

# 目錄

**P.5** 三爪中空油壓夾頭  
3-JAW WEDGE TYPE THROUGH-HOLE  
POWER CHUCK (WITHOUT ADAPTOR)

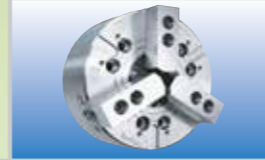

**P.6** 三爪高速中空油壓夾頭  
3-JAW WEDGE TYPE THROUGH-HOLE  
POWER CHUCK (WITH ADAPTOR)



**P.7** 大孔徑三爪高速中空油壓夾頭  
3-JAW WEDGE TYPE THROUGH-HOLE  
POWER CHUCK (WITH ADAPTOR) (BIG HOLE)



**P.8** 二爪中空油壓夾頭  
2-JAW WEDGE TYPE THROUGH-HOLE  
POWER CHUCK (WITHOUT ADAPTOR)



**P.9** 四爪中空油壓夾頭  
4-JAW WEDGE TYPE THROUGH-HOLE  
POWER CHUCK (WITH ADAPTOR)



**P.10** 三爪中實油壓夾頭  
3-JAW WEDGE TYPE NON THROUGH-  
HOLE POWER CHUCK (WITHOUT ADAPTOR)



**P.11** 三爪中實油壓夾頭  
3-JAW WEDGE TYPE NON THROUGH-  
HOLE POWER CHUCK (WITH ADAPTOR)



**P.12** 二爪中實油壓夾頭  
2-JAW WEDGE TYPE NON THROUGH-  
HOLE POWER CHUCK (WITHOUT ADAPTOR)



**P.13** 立式油壓夾頭系列  
VERTICAL POWER CHUCK

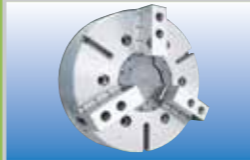

**P.14** 三爪中實防水夾頭  
3-JAW WEDGE TYPE NON THROUGH-HOLE  
WATERPROOF POWER CHUCK (WITH ADAPTOR)



**P.15** 高速中空迴轉油壓缸  
SUPER HIGH SPEED THROUGH-HOLE  
ROTARY HYDRAULIC CYLINDER



**P.16** 超·薄·型油壓缸  
SHORT TYPE CYLINDER



**P.17** 中實迴轉油壓缸  
NON THROUGH-HOLE ROTARY HYDRAULIC  
CYLINDER



**P.18** 中實迴轉油壓缸  
NON THROUGH-HOLE ROTARY HYDRAULIC  
CYLINDER



**P.19** 中實迴轉油壓缸  
NON THROUGH-HOLE ROTARY HYDRAULIC  
CYLINDER



**P.20** 迴轉油壓缸集水槽  
HYDRAULIC CYLINDER COOLANT  
COLLECTOR



**P.21** 標準硬爪  
STANDARD HARD JAW



**P.22** 標準生爪  
STANDARD SOFT JAW



**P.23** 動力精密套筒夾頭  
POWER OPERATED COLLET CHUCK



**P.24** 彈性筒夾  
STEEL COLLET



**P.24** 動力精密套筒夾頭  
POWER OPERATED  
COLLET CHUCK



**P.25** 動力精密套筒夾頭  
POWER OPERATED COLLET CHUCK

## 公司沿革 History

- 1989年** ● 通福創立，工廠創立於台中市東山路，專業從事大孔徑中空油壓夾盤，及超高速中空迴轉油壓缸之研發測試。  
● Ton Fou was established, factory was located on Tung San Rd., Taichung. The products were large bore hollow hydraulic chucks and high speed hydraulic hollow cylinders.
- 1990年** ● 研發成功新機發表並在短時間內，獲得市場極高的評價肯定，擴大產能工廠遷移至太平市中山路。  
● New product was launched and earn a high reputation in the marketplace. In order to extend our production, the factory was moved to Chung San Rd. in Tai Pin City.
- 1996年** ● 通過英國 AMTRI CE MARK 認證。  
● Approved to CE-MARK Certificate by AMTRI VERTAS.
- 1997年** ● 榮獲中華民國空油壓公會經營卓越獎。為滿足市場需求擴大產能，遷移太平市鵬儀路新廠，擴大營業。  
● Obtained the excellent award of Taiwan Hydraulic & Pneumatic Association. The factory was expanded again and relocated to Pan I Rd. in Tai Pin City.
- 1999年** ● 通過英國 AMTRI, ISO-9002 認證。  
● Approved with ISO 9002 quality certificate by U.K. AMTRI.
- 2001年** ● 夾盤及迴轉油壓缸榮獲「台灣精品獎」。  
● Awarded "It's very best made in Taiwan" for chucks and cylinders.
- 2005年** ● ISO 9001 認證。  
● Approved with ISO 9001 quality certificate by U.S.A. NSF.
- 2010年** ● 金融海嘯之後，景氣復甦，市場需求增加。為滿足市場需求，提高產能及品質，再次擴大營業遷移至大里區大里路新廠服務。  
● After financial tsunami, the economics recovered and the market demand increased. To satisfy the market and raise quality, the factory was expanded again and relocated to Da Li Rd in Da Li District.



## 研發及品保系統 R&D and Quality Assurance:



## Tonfou® 三爪中空油壓夾頭 (不含連接板)

### 3-JAW WEDGE TYPE THROUGH-HOLE POWER CHUCK (WITHOUT ADAPTOR)

# TF3B SERIES

Serration Pitch  
4"-18":1.5x60°  
21", 24":3.0x60°

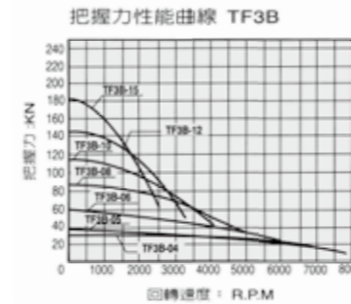
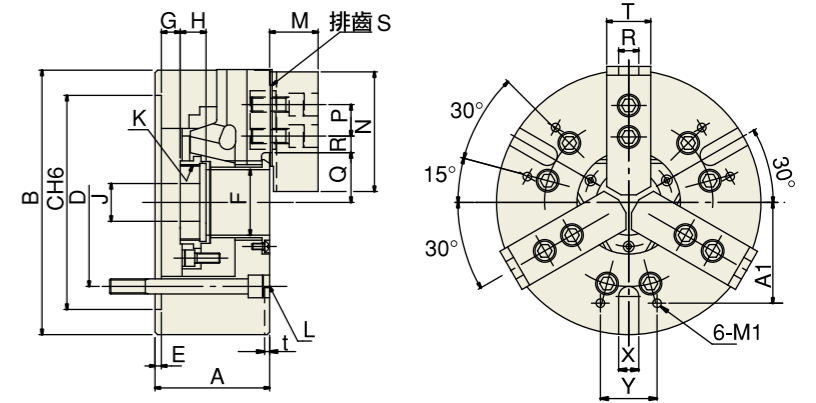

### 規格 SPECIFICATIONS

性能 Specification	型式 Model	TF3B									
		4	5	6	8	10	12	15	18	21	24
爪行程 (齒徑) Jaw Stroke (Dia) (mm)		5.4	5.4	5.5	7.4	8.8	10.6	10.6	10.6	13	13
柱塞行程 Plunger Stroke (mm)		10	10	12	16	19	23	23	23	28	28
最大、最小把握徑 Recommended external chucking Diameter for standard soft top jaw(mm)	最大Max. 最小Min.	110 5	135 10	165 10	210 12	254 16	304 38	381 40	450 40	530 50	610 50
最高使用迴轉速 Max. speed	(r.p.m)	8000	7000	6000	4900	4200	3300	2600	2000	1700	1400
最大拉桿推力 Max. Draw Bar Pull Force	KN (kgf)	14 (1428)	17.5 (1784)	22 (2243)	34 (3467)	43 (4385)	55 (5608)	71 (7240)	71 (7240)	90 (9177)	90 (9177)
把握力 Clamping-force at Max. Draw Bar pull (Total jaw force)	KN (kgf)	28.5 (2906)	36 (3671)	57 (5812)	86 (8769)	111 (11319)	144 (14686)	180 (18355)	180 (18355)	234 (23861)	234 (23861)
GD <sup>2</sup> Moment of inertia	(kgf-m <sup>2</sup> )	0.007	0.0018	0.057	0.167	0.315	0.737	2.273	4.776	9.25	16.85
重量 Weight with standard soft top jaws	(kg)	4	6.7	12.5	22.6	37	61	120	166	229	287
搭配油壓缸 Matching cylinder	最高使用壓力 Max. pressure to operate chuck(kg/cm <sup>2</sup> )	RC 4 / 24.5	5 / 29.5	6 / 28.5	8 / 27	10 / 27.5	12 / 27.5	15 / 23.5	15 / 23.5	15 / 30.5	15 / 30.5

### 尺寸表 DIMENSIONS

規格 代號 Series Symbo	TF3B										
	4	5	6	8	10	12	15	18	21	24	
A	59	60	81	91	100	110	133	133	148	148	
B	110	135	169	210	254	304	381	450	530	610	
CH6	85	110	140	170	220	220	300	300	380	380	
D	70.6	82.55	104.78	133.35	171.45	171.45	235	235	330.2	330.2	
E	4	4	5	5	5	6	6	6	6	6	
F	26	33	45	52	75	91	117.5	117.5	170	170	
G	Max	3.5	1	11	14.5	8.5	8	23	11	16	16
	Min	-6.5	-9	-1	-1.5	-10.5	-15	0	-12	-12	-12
H	17.5	20	19	20.5	25	28	35	39	40	40	
J	12	12	20	30	45	50	50	50	50	50	
K	Max	M32x1.5	M40x1.5	M55x2	M60x2	M85x2	M100x2	M130x2.0	M130x2.0	M180x3.0	M180x3.0
L		3-M10x60	3-M10x60	6-M10x80	6-M12x90	6-M16x100	6-M16x110	6-M20x150	6-M20x150	6-M22x170	6-M22x170
M	24	26	29	39	43	51	61	70	70	70	
N	49.5	54	66	95	110	111	135	135	185	185	
P	14	14	20	25	30	30	43	43	60	60	
Q	Max	23	26.5	32	38.7	51	61.3	70	82	108	108
	Min	20.3	23.8	29.25	35	46.6	56	64.7	76.7	101.5	101.5
R	Max	11.25	19.75	22.75	29.75	33.75	45.75	54.75	78.25	117.5	117.5
	Min	6.75	7.75	9.25	14.75	14.25	15.75	20.25	18.25	21.5	21.5
S	1.5	1.5	1.5	1.5	1.5	1.5	1.5	1.5	3.0	3.0	
T	23	23	32	37	40	50	50	50	62	62	
X	-	12	16	16	16	20	20	20	20	20	
Y	-	30	36	45	60	60	80	80	100	100	
A1	-	52	65	80	102	100	150	150	200	200	
M1	-	M6	M8	M8	M10	M10	M12	M12	M12	M12	
t	-	5	5	5	5	5	5	5	5	5	

# TF-3BA SERIES

## 3-JAW WEDGE TYPE THROUGH-HOLE POWER CHUCK (WITH ADAPTOR)

Serration Pitch  
4"-18":1.5x60°  
21", 24":3.0x60°

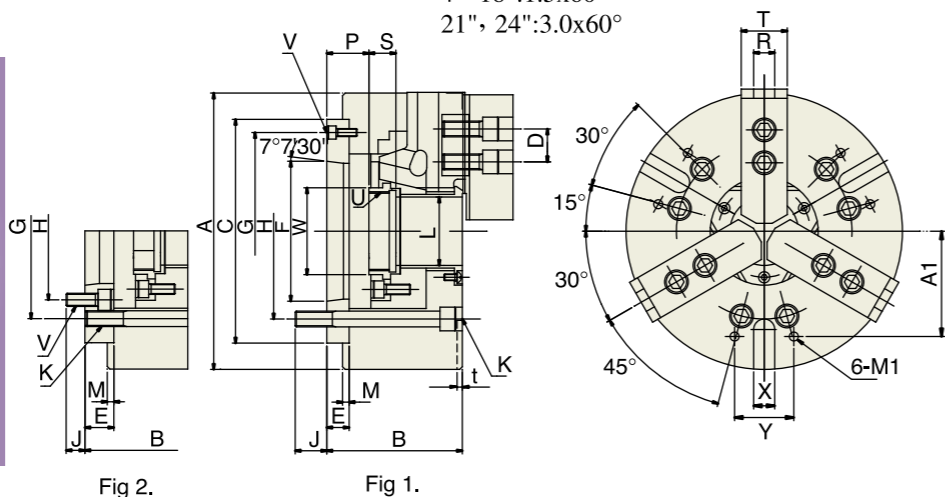
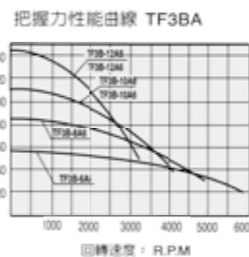

Fig 2.

Fig 1.

### 規格 SPECIFICATIONS

尺寸 Dim	TF3B-5A4	TF3B-6A5	TF3B-8A5	TF3B-8A6	TF3B-10A6	TF3B-10A8	TF3B-12A8	TF3B-15A8	TF3B-15A11	TF3B-18A11	TF3B-21A11	TF3B-21A15	TF3B-24A11	TF3B-24A15
通孔徑 Through-Hole (mm)	33	45	52	52	75	75	91	117.5	117.5	117.5	170	170	170	170
柱塞行程 Plunger Stroke (mm)	10	12	16	16	19	19	23	23	23	23	28	28	28	28
爪行程 (直徑) Jaw Stroke (Dia) (mm)	5.4	5.5	7.4	7.4	8.8	8.8	10.6	10.6	10.6	10.6	13	13	13	13
最大拉桿推力 Max. Draw Bar Pull Force (kgf)	1700	2200	3400	3400	4300	4300	5500	7240	7240	7240	9177	9177	9177	9177
最大夾持力/油壓壓力 Max. Gripping Force (kgf)/(kgf/cm <sup>2</sup> )	3600/29.6	5700/28.5	8800/26.5	8800/26.5	11000/27.5	11000/27.5	14300/27.5	18355/23.5	18355/23.5	18355/23.5	23861/30.5	23861/30.5	23861/30.5	23861/30.5
最大速度 Max. Speed (r.p.m)	7000	6000	4900	4900	4200	4200	3300	2500	2500	2000	1700	1700	1400	1400
重量 Weight (kg)	6.9	14.2	25.8	24.05	40.9	37.4	59.5	134	127	171	238	235	296	293
適合油壓缸 Matching Cylinder	RC5	RC6	RC8	RC8	RC10	RC10	RC12	RC15	RC15	RC15	RC15	RC15	RC15	RC15
適合生爪 Matching Soft Jaw	HC05	HC06	HC08	HC08	HC10	HC10	HC12	HC15	HC15	HC15	HC21	HC21	HC21	HC21
適合硬爪 Maching Hard Jaw	HJ05	HJ06	HJ08	HJ08	HJ10	HJ10	HJ12	HJ15	HJ15	HJ15	HJ21	HJ21	HJ21	HJ21



### 尺寸表 DIMENSIONS

尺寸 Dim	TF3B-5A4	TF3B-6A5	TF3B-8A5	TF3B-8A6	TF3B-10A6	TF3B-10A8	TF3B-12A6	TF3B-12A8	TF3B-15A8	TF3B-15A11
A	135	169	210	210	254	254	304	304	381	381
B	71	91	109	103	120	113	129	122	160	149
G(H6)	96	116	133.35	150	171.45	190	190	190	235	260
D	14	20	25	25	30	30	30	30	43	43
E	15	15	22	17	25	18	25	18	33	22
F	63.513	82.563	82.563	106.375	106.375	139.719	106.375	139.719	139.719	196.869
C(H6)	110	140	170	170	220	220	220	220	300	300
H	82.55	104.78	104.78	133.35	133.35	171.45	133.35	171.45	171.45	235
J	15.5	16	19	19	24	25	24	24	28	28
K	3XM10	6XM10	6X12	6XM12	6XM16	6XM16	6XM16	6XM16	6XM20	6XM20
L	33	45	52	52	75	91	91	91	117.5	117.5
M	4	5	5	5	5	5	6	6	6	6
P max.	16	26	37.5	31.5	33.5	26.5	33	26	40	34
P min.	6	14	21.5	15.5	14.5	7.5	10	3	17	11
R	10	12	14	14	16	16	21	21	24	24
S	20	19	20.5	20.5	25	25	28	28	39	39
T	23	32	37	37	42	42	52	52	62	62
U max.	M40X1.5	M55X2.0	M60X2.0	M60X2.0	M85X2.0	M85X2.0	M100X2.0	M100X2.0	M130X2.0	M130X2.0
V	3XM6	3XM6	6XM10	3XM6	6XM12	6XM8	6XM12	6XM8	6XM16	3XM10
W	45	60	66	66	94	94	108	108	139	139
X	12	16	16	16	16	16	20	20	20	20
Y	30	36	45	45	60	60	60	60	80	80
A1	52	65	80	80	102	102	100	100	150	150
M1	M6	M8	M8	M8	M10	M10	M10	M10	M12	M12
t	5	5	5	5	5	5	5	5	5	5
Reference	Fig 1	Fig 1	Fig 2	Fig 1	Fig 2	Fig 1	Fig 2	Fig 1	Fig 2	Fig 1

尺寸 Dim	TF3B-18A11	TF3B-21A11	TF3B-21A15	TF3B-24A11	TF3B-24A15
A	450	530	530	610	610
B	149	183	169	183	169
G	260	330.2	330.2	330.2	330.2
D	43	60	60	60	60
E	22	41	27	41	27
F	196.869	196.869	285.75	196.869	285.75
C(H6)	300	380	380	380	380
H	235	330.2	330.2	330.2	330.2
J	28	30	30	30	30
K	6XM20	6XM22	6XM22	6XM22	6XM22
L	117.5	170	170	170	170
M	6	6	6	6	6
X	20	20	20	20	20
Y	80	100	100	100	100

尺寸 Dim	TF3B-18A11	TF3B-21A11	TF3B-21A15	TF3B-24A11	TF3B-24A15
P max.	33	57	43	57	43
P min.	10	29	15	29	15
R	24	25	25	25	25
S	39	40	40	40	40
T	62	65	65	65	65
U max.	M130X2.0	M180X3.0	M180X3.0	M180X3.0	M180X3.0
V	3XM10	6XM12	6XM12	6XM12	6XM12
W	139	207	207	207	207
A1	150	200	200	200	200
M1	M12	M12	M12	M12	M12
t	5	5	5	5	5
Reference	Fig 1	Fig 2	Fig 1	Fig 2	Fig 1

# TF-3CA / TF-3XA SERIES

## 3-JAW WEDGE TYPE THROUGH-HOLE POWER CHUCK (WITH ADAPTOR) (BIG HOLE)

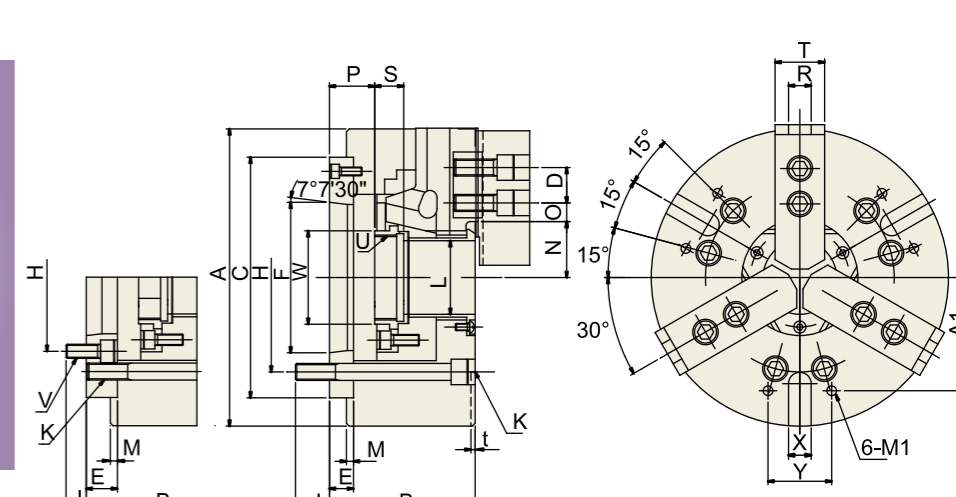

Fig 2

Fig 1

### 規格 SPECIFICATIONS

尺寸 Dim	TF3C-6A5	TF3C-8A6	TF3X-10A8	TF3X-12A8	TF3X-12A11
通孔徑 Through-Hole (mm)	52	66	78	100	100
柱塞行程 Plunger Stroke (mm)	12	17	19	23	23
爪行程 (直徑) Jaw Stroke (Dia) (mm)	5.5	7.4	8.8	10.6	10.6
最大拉桿推力 Max. Draw Bar Pull Force (kgf)	2200	3400	4300	5500	5500
最大夾持力/油壓壓力 Max. Gripping Force (kgf)/(kgf/cm <sup>2</sup> )	5700/18	8700/18	11000/27.5	14300/19.5	14300/19.5
最大速度 Max. Speed (r.p.m)	6000	4600	4200	3300	3300
重量 Weight (kg)	14.2	24.5	37.4	61	61
適合油壓缸 Matching Cylinder	RCS-8	RCS-10	RCS-10X	RC15	RC15
適合生爪 Matching Soft Jaw	HC06	HC08	HC10	HC12	HC12
適合硬爪 Matching Hard Jaw	HJ06	HJ08	HJ10	HJ12	HJ12

### 尺寸表 DIMENSIONS

尺寸 Dim	TF3C-6A5	TF3C-8A6	TF3X-10A8	TF3X-12A8	TF3X-12A11
A	175	215	254	318	318
B	75	108.5	113	137	126
D	20	25	30	30	30
E	30	22.5	18	33	22
F	82.563	106.36	139.719	139.719	196.8
C(H6)	140	170	220	300	300
H	104.78	133.4	171.45	171.45	235
J	16	16	20	20	20
K	6XM10	6-M12	6XM16	6XM20	6XM20
L	52	66	78	110	110
M	5	7	5	6	6
N max.	32	46	51	68	68
N min.	29.25	42	46.6	63	63
O max.	24	25.5	34.5	53.5	53.5
O min.	7.5	10.5	12	19	19
P max.	25	12.5	26.5	37	26
P min.	12.5	-4.5	7.5	14	3
R	12	14	16	21	21
S	19	25	25	28	28
T	32	37	42	52	52
U max.	M60X2.0	M74XP2.0	M87X2.0	M115X2.0	M115X2.0
V	—	—	—	6XM16	—
W	66	82	96	127	127
X	16	16	20	20	20
Y	36	45	60	60	60
A1	65	80	102	140	140
M1	M8	M8	M10	M10	M10
t	5	5	5	5	5
Reference	Fig. 1	Fig. 1	Fig. 1	Fig. 2	Fig. 1

2-JAW WEDGE TYPE THROUGH-HOLE POWER CHUCK (WITHOUT ADAPTOR)

TF2B SERIES

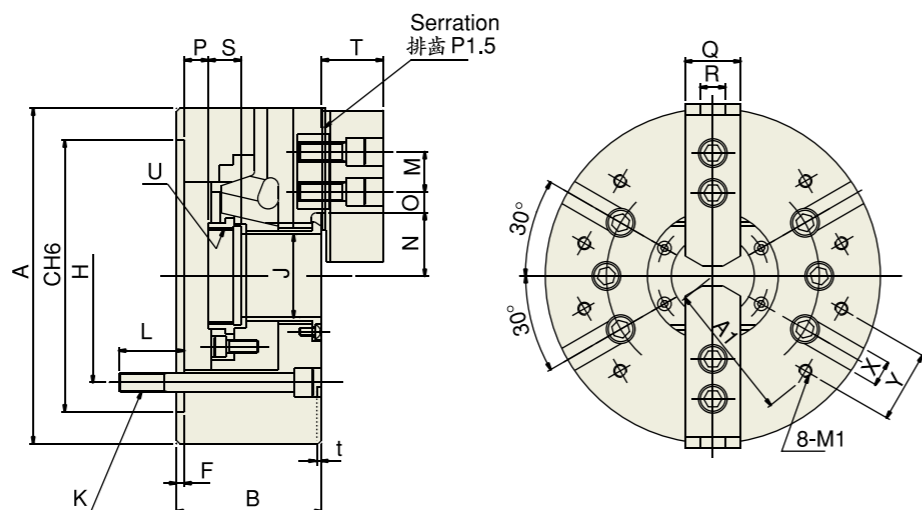

規格 SPECIFICATIONS

型式 Model	尺寸 Dim	TF2B							
		4	5	6	8	10	12	15	
爪行程 (直徑) Jaw Stroke (Dia) (mm)	(mm)	5.4	5.4	5.5	7.4	8.8	10.6	10.6	
柱塞行程 Plunger Stroke	(mm)	10	10	12	16	19	23	23	
最大、最小把握徑 Recommended external chucking Diameter for standard soft top Jaw (mm)	最大 Max.	110	135	165	210	210	304	381	
	最小 Min.	10	10	10	12	16	38	40	
最高使用迴轉速 Max. Speed	(r.p.m)	8000	7000	6000	4900	4200	3300	2500	
最高拉桿推力 Max. Draw Bar Pull Force	(kgf)	948	1158	1450	2250	2850	3667	4793	
把握力 Clamping-force at Max. Draw Bar pull (Total jaw force)	(kgf)	1935	2399	3800	5600	7400	9600	12236	
慣性矩 GD <sup>2</sup> Moment of inertia	(kgf.m <sup>2</sup> )	0.006	0.0017	0.056	0.165	0.308	0.7	2.30	
重量 Weight with standard soft top jaws	(kg)	3.8	6.5	11.5	21.3	33.5	52	115	
搭配油壓 Matching Cylinder	RC	4 / 23	5 / 16	6 / 19	8 / 17.5	10 / 18.5	12 / 18.5	15 / 15.3	
	最高使用壓力 Max. pressure to operate chuck (kgf/cm <sup>2</sup> )								

尺寸表 DIMENSIONS

尺寸 Dim	代號 Symbol	A	B	C (H6)	F	H	J	K	L	M	N		O		P		Q	R	S	T	U max	X	Y	A1	M1	t
											Max.	Min.	Max.	Min.	Max.	Min.										
TF2B	4	110	59	85	4	70.6	26	M10	16	14	23	20.3	11.25	6.75	3.5	-6.5	23	10	17.5	24	M32X1.5	-	-	-	-	-
	5	135	60	110	4	82.55	33	6-M10	16	14	26.5	23.8	19.5	6	16	6	23	10	20	26	M40X1.5	12	30	52	M6	5
	6	169	81	140	5	104.78	45	6-M12	20	20	32	29.54	24	7.5	11	-1	32	12	19	29	M55X2.0	16	36	65	M8	5
	8	210	91	170	5	133.35	52	6-M12	22	25	38.7	35	30	10.5	14.5	-1.5	37	14	23.5	39	M60X2.0	16	45	80	M8	5
	10	254	100	220	5	171.45	75	6-M16	23	30	51	46.6	34.5	12	8.5	-10.5	42	16	25	43	M85X2.0	16	60	102	M10	5
	12	304	110	220	6	171.45	91	6-M16	30	30	61.3	56	46.5	12	8	-15	52	21	28	51	M100X2.0	20	60	100	M10	5
	15	381	133	300	6	235	117.5	6-M10	16	43	82	76.7	46.5	13.5	23	0	62	24	43	66	M130X2.0	20	80	150	M12	5

4-JAW WEDGE TYPE THROUGH-HOLE POWER CHUCK (WITH ADAPTOR)

TF-4BA SERIES

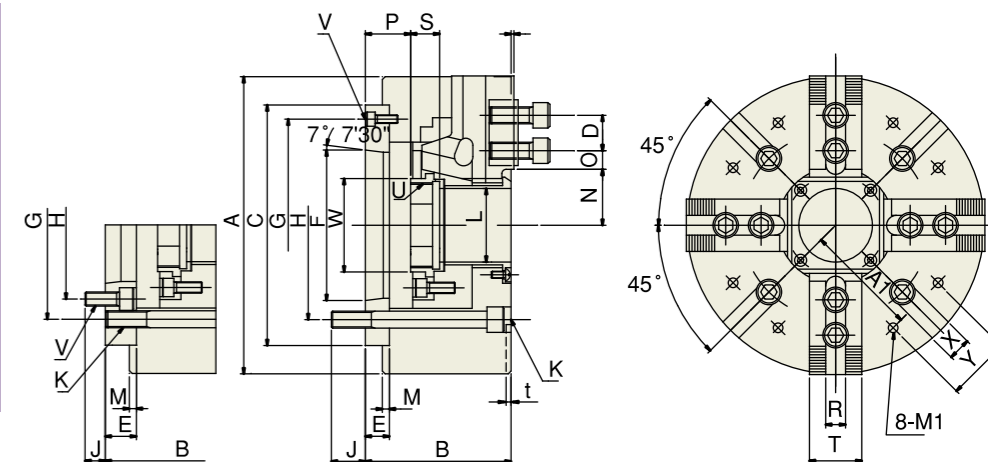

尺寸表 DIMENSIONS

型式 model	TF4B- 6A5	TF4B- 8A5	TF4B- 8A6	TF4B- 10A6	TF4B- 10A8	TF4B- 12A8	TF4B- 15A8	TF4B- 15A11
A	169	210	210	254	254	304	381	381
B	91	109	103	120	113	122	160	163
G	116	133.35	150	171.45	190	190	235	260
D	20	25	25	30	30	30	43	43
E	15	23	17	25	18	18	33	22
F	82.563	82.563	106.375	106.375	139.719	139.719	196.869	196.869
C(H6)	140	170	170	220	220	220	300	300
H	104.78	104.78	133.35	133.35	171.45	171.45	171.45	235
J	16	13	18	18	24	25	24	28
K	4XM10	4XM12	4XM12	4XM16	4XM16	4XM16	4XM20	4XM20
L	45	52	52	75	75	91	117.5	117.5
M	5	5	5	5	5	6	6	6
N max.	32	38.7	38.7	51	51	61.3	82	82
N min.	29.25	35	35	46.6	46.6	56	76.7	76.7
O max.	24	30	30	34.5	34.5	46.5	46.75	46.75
O min.	75	10.5	10.5	12	12	12	13.75	13.75
P max.	26	37.5	31.5	33.5	26.5	26	40	29
P min.	14	22.5	15.5	14.5	7.5	3	17	6
R	12	14	14	16	16	21	24	24
S	19	20.5	20.5	25	25	28	43	43
T	32	37	37	42	42	52	62	62
U max.	M55X2.0	M60X2.0	M60X2.0	M85X2.0	M85X2.0	M100X2.0	M130X2.0	M130X2.0
V	4XM6	4XM6	4XM6	6XM12	4XM8	4XM8	4XM10	4XM10
W	60	66	66	94	94	108	139	139
X	16	16	16	16	16	20	20	20
Y	36	45	45	60	60	60	80	80
A1	65	80	80	102	102	100	150	150
M1	M8	M8	M8	M10	M10	M10	M12	M12
t	5	5	5	5	5	5	5	5
參考圖 Reference	Fig. 1	Fig. 2	Fig. 1	Fig. 2	Fig. 1	Fig. 1	Fig. 2	Fig. 1

3-JAW WEDGE TYPE NON THROUGH-HOLE POWER CHUCK (WITHOUT ADAPTOR)

V SERIES

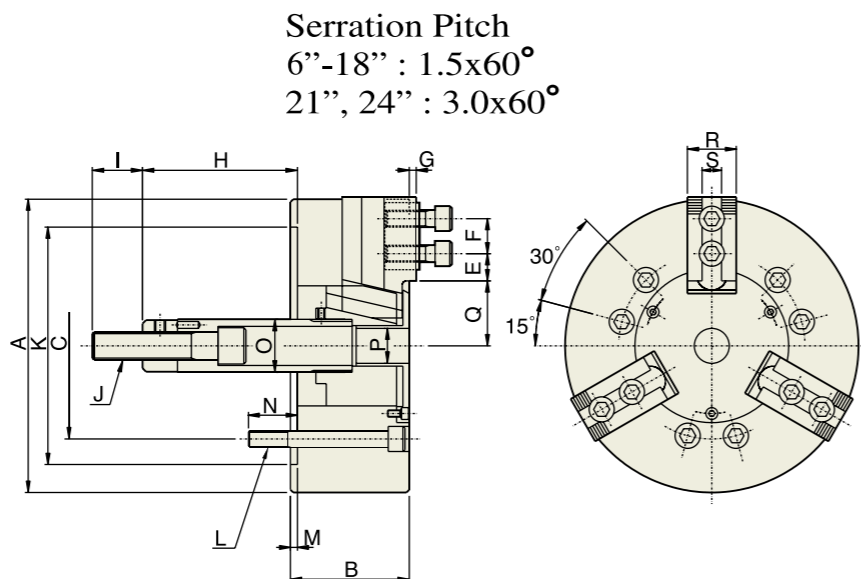

規格 SPECIFICATIONS

型式 Model	V-206	V-208	V-210	V-212	V-215	V-218	V-221	V224
爪行程 (直徑) Jaw Stroke (Dia) (mm)	8.5	8.8	8.8	10.5	16	16	16	16
柱塞行程 Plunger Stroke (mm)	20	21	25	30	35	35	35	35
夾持範圍 Gripping Range	最大 Max (mm)	165	210	254	304	381	450	610
	最小 Min (mm)	12	12	16	18	68	40	50
最大推力 Max. Pull Force (kgf)	1835	2549	2957	4181	8362	8362	8362	8362
最高轉速 Max. Speed (r.p.m)	5000	4000	3500	3000	2800	2700	1900	1750
最大夾持力/油壓壓力 Max. Gripping Force (kgf)/(kgf/cm <sup>2</sup> )	5253/25.5	7548/24.5	11013/28.6	15807/27.5	25391/32.6	25391/32.6	25391/32.6	25391/32.6
重量 Weight (kg)	12	22.8	34.4	59	100.6	126	187	225
慣性矩 Moment of Inertia (kgf.m <sup>2</sup> )	0.045	0.137	0.3	0.725	1.8	2.35	4.80	6.92
適合油壓缸 Matching Cylinder	MH100	MH125	MH125	MH150	MH200	MS-200	MS-200	MS-200
適合之硬爪 Matching Hard Jaw	HJ06	HJ08	HJ10	HJ12-1	HJ15-1	HJ15-1	HJ21-1	HJ21-1
適合之軟爪 Matching Soft Jaw	HC06	HC08	HC10	HC12-1	HC15-1	HC15-1	HC21-1	HC21-1

尺寸表 DIMENSIONS:

型式 Model	V-206	V-208	V-210	V-212	V-215	V-218	V-221	V224
A	165	210	254	304	318	450	530	610
B	74	85	89	106	114	114	125	125
K(H6)	140	170	220	220	300	300	380	380
M	5	5	5	6	6	6	6	6
C	104.78	133.35	171.45	171.45	235	235	330.2	330.2
P	21	25	34	34	-	-	-	-
L	6-M10	6-M12	6-M16	6-M16	6-M20	6-M20	6-M24	6-M24
N	14	20	18	22	29	29	31	31
F	20	25	30	30	43	43	60	60
Q	Max.	37.8	46.3	51.1	61	77.5	108	86.5
	Min.	33.55	41.9	46.7	55.75	69.5	100	78.5
E	Max.	18	22.5	37.5	47	50.25	93	93
	Min.	7.5	9	10.5	11	23.25	24	24
H	Max.	104.6	132	158	163	104	92	97
	Min.	84.6	111	133	133	69	57	62
S	12	14	16	18	25.5	25.5	25	25
R	31	35	40	50	50	50	65	65
J	M16X2.0	M20X2.5	M20X2.5	M20X2.5	M30X3.5	M30X3.5	M30X3.5	M30X3.5
G	4	5	5	5	2	2	7.5	7.5
O	34	38	45	50	60	60	60	60
I	36	36	36	36	55	55	55	55

3-JAW WEDGE TYPE NON THROUGH-HOLE POWER CHUCK (WITH ADAPTOR)

VA SERIES

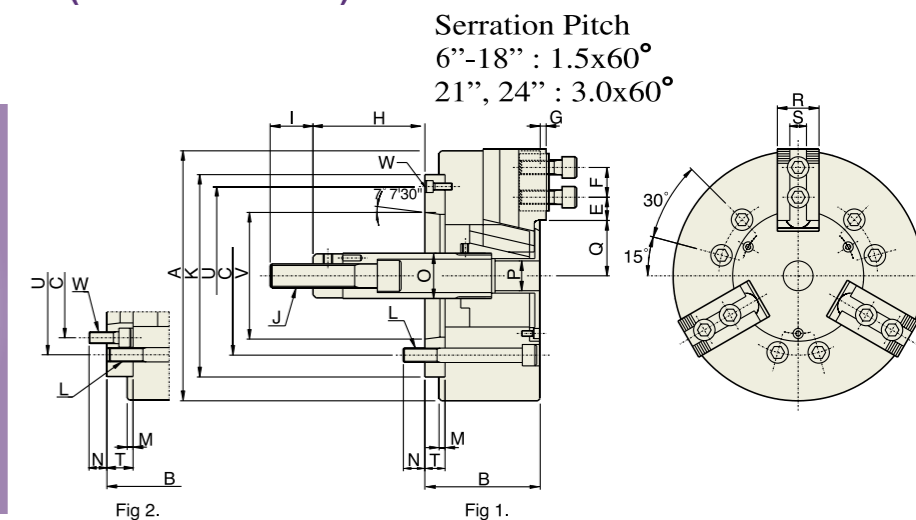

規格 SPECIFICATIONS

型式 Model	爪行程 (直徑) Jaw Stroke (Dia) (mm)	柱塞行程 Plunger Stroke (mm)	最大推力 Max. Pull Force (kgf)	最大夾持力/油壓壓力 Max. Gripping Force (kgf)/(kgf/cm <sup>2</sup> )	最高轉速 Max. Speed (r.p.m)	重量 Weight (kg)	慣性矩 Moment of Inertia (kgf.m <sup>2</sup> )	適合油壓缸 Matching Cylinder	適合之軟爪 Matching Soft Jaw	適合之硬爪 Matching Hard Jaw
V-206A5	8.5	20	1835	5253/25.5	5270	12.5	0.045	MH105	HC06	HJ06
V-208A6	8.8	21	2549	7548/24.5	4765	24.4	0.137	MH125	HC08	HJ08
V-210A6	8.8	25	2957	10013/28.6	4010	40.65	0.3	MH125	HC10	HJ10
V-210A8	8.8	25	2957	10013/28.6	4010	37.15	0.3	MH125	HC10	HJ10
V-212A8	10.5	30	4181	15807/27.5	3380	61.75	0.725	MH150	HC12-1	HJ12-1
V-215A8	16	35	8362	25391/30.6	3000	105	1.8	MH150	HC15-1	HJ15-1
V-215A11	16	35	8362	25391/32.6	3000	103	1.8	MH200	HC15-1	HJ15-1
V-218A8	16	35	8362	25391/32.6	2700	134	2.41	MS-200	HC15-1	HJ15-1
V-218A11	16	35	8362	25391/32.6	2700	123	2.11	MS-200	HC15-1	HJ15-1
V-221A11	16	35	8362	25391/32.6	1900	193	5.1	MS-200	HC21-1	HJ21-1
V-221A15	16	35	8362	25391/32.6	1900	187	4.9	MS-200	HC21-1	HJ21-1
V-224A11	16	35	8362	25391/32.6	1750	239	7.5	MS-200	HC21-1	HJ21-1
V-224A15	16	35	8362	25391/32.6	1750	233	7.1	MS-200	HC21-1	HJ21-1

尺寸表 DIMENSIONS

型式 Model	V-206 A5	V-208 A5	V-210 A6	V-210 A6	V-210 A8	V-212 A8	V-215 A8	V-215 A11	V-218 A8	V-218 A11	V-221 A11	V-221 A15	V-224 A11	V-224 A15
A	165	210	210	254	254	304	381	381	450	450	530	530	610	610
B	84	103	97	109	102	118	141	130	141	130	146	146	146	146
C	104.78	104.78	133.35	133.35	171.45	171.45	171.45	235	171.45	235	235	330.2	235	330.2
F	20	25	25	30	30	30	43	43	43	43	60	60	60	60
K	140	170	170	220	220	220	300	300	300	300	380	380	380	380
L	6-M10	6-M12	6-M12	6-M16	6-M16	6-M16	6-M16	6-M20	6-M16	6-M20	6-M20	6-M24	6-M24	6-M24
M	5	5	5	5	5	6	6	6	6	6	6	6	6	6
N	14	13	18	18	25	25	24	32	24	32	28	34	28	34
P	21	21	25	34	34	34	-	-	-	-	-	-	-	-
T	15	23	17	25	18	18	33	22	33	22	27	27	27	27
V	82.563	82.563	106.375	106.375	139.719	139.719	139.719	196.869	139.719	196.869	196.869	285.75	196.869	285.75
U	116	133.35	150	171.45	190	190	235	260	235	260	330.2	330.2	330.2	330.2
E	Max.	18	22.5	22.5	37.5	37.5	47	50.25	50.25	50.25	93.5	93.5	93.5	93.5
	Min.	7.5	9	9	10.5	10.5	11	23.25	23.25	23.25	24.5	24.5	24.5	24.5
G	4	5	5	5	5	5	2	2	3	3	3	3	3	3
H	Max.	89.6	109	115	133	140	145	71	82	59	70	70	70	70
	Min.	69.6	88	94	108	115	115	36	47	24	35	35	35	35
I	36	36	36	36	36	36	55	55	55	55	55	55	55	55
J	M16x2.0	M20x2.5	M20x2.5	M20x2.5	M20x2.5	M20x2.5	M30x3.5	M30x3.5	M30x3.5	M30x3.5	M30x3.5	M30x3.5	M30x3.5	M30x3.5
O	34	38	38	45	45	50	60	60	60	60	60	60	60	60
Q	Max.	37.8	46.3	46.3	51.1	51.1	61	77.5	77.5	108	108	86	86	125
	Min.	33.5	41.9	41.9	46.7	46.7	55.75	69.5	69.5	100	100	78	78	117
R	31	35	35	40	40	50	50	50	50	50	65	65	65	65
S	12	14	14	16	16	18	25.5	25.5	25.5	25.5	25	25	25	25
W	3-M6	3-M10	3-M6	6-M12	6-M8	6-M8	6-M16	3-M10	6-M20	3-M10	6-M20	3-M12	6-M20	3-M12
Reference	Fig-1	Fig-2	Fig-1	Fig-2	Fig-1	Fig-1	Fig-2	Fig-1	Fig-2	Fig-1	Fig-1	Fig-1	Fig-2	Fig-1

2-JAW WEDGE TYPE NON THROUGH-HOLE POWER CHUCK (WITHOUT ADAPTOR)

VT SERIES

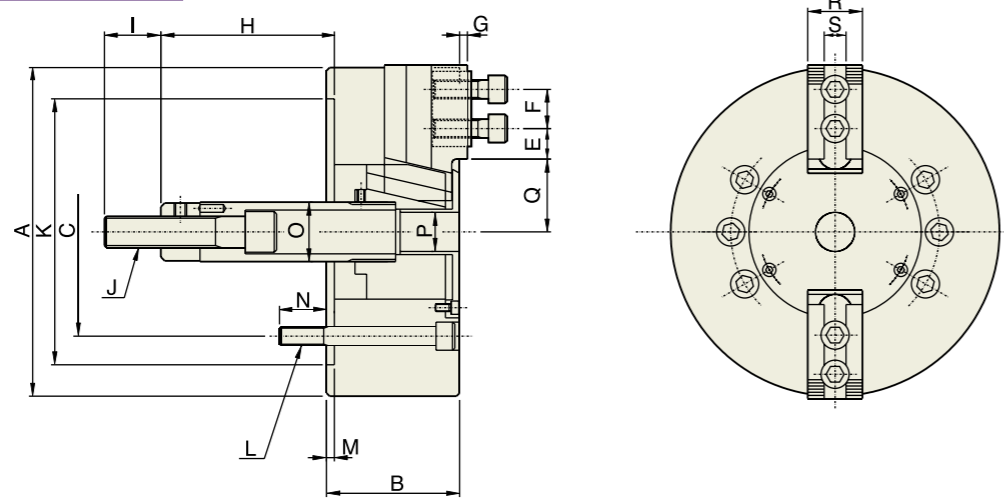

規格 SPECIFICATIONS

尺寸 Dim	型式 Model	VT-206	VT-208	VT-210	VT-212	VT-215
爪行程 Jaw Stroke (Dia) (mm)		8.5	8.8	8.8	10.5	16
柱塞行程 Plunger Stroke (mm)		20	21	25	30	35
夾持範圍 Gripping Range	最大 Max (mm)	165	210	254	304	381
	最小 Min (mm)	18	22	24	25	68
最大推力 Max. Pull Force KN(kgf)		12(1224)	16.5(1683)	19.5(1988)	27.5(2804)	55(5609)
最大夾持力 Max. Gripping Force KN (kgf)		34(3469)	50(5099)	72(7242)	104(10505)	166(16827)
最高轉度 Max. Speed (r.p.m)		5100	4650	3810	3200	2800
重量 Weight (kg)		12	22	33	57.3	96
慣性矩 Moment of Inertia (kg.m <sup>2</sup> )		0.04	0.13	0.29	0.7	1.7
適合油壓缸 Matching Cylinder		MH100	MH125	MH125	MH150	MH200
適合之軟爪 Maching Soft Jaw		HC06	HC08	HC10	HC12-1	HC15-1
適合之硬爪 Matching Hard Jaw		HJ06	HJ08	HJ10	HJ12-1	HJ15-1

尺寸表 DIMENSIONS

尺寸 Dim	型式 Model	VT-206	VT-208	VT-210	VT-212	VT-215
A		165	210	254	304	381
B		74	85	89	106	114
C		104.78	133.35	171.45	171.45	235
E	Max.	18	22.5	37.5	47	50.25
	Min.	7.5	9	10.5	11	23.25
F		20	25	30	30	43
G		4	5	5	5	2
H	Max.	106.5	132	163	168	104
	Min.	86.5	111	138	138	69
I		36	36	36	36	55
J		M16x2.0	M20x2.5	M20x2.5	M20x2.5	M30x3.5
K(H6)		140	170	220	220	300
L		6-M10	6-M12	6-M16	6-M16	6-M20
M		5	5	5	6	6
N		14	20	18	22	29
O		34	38	45	50	60
P		21	25	34	34	-
Q	Max.	37.8	46.3	51.1	61	77.5
	Min.	33.5	41.9	46.7	55.75	69.5
R		31	35	40	50	50
S		12	14	16	18	25.5

VERTICAL POWER CHUCK

DOV SERIES



- 適合立式、鉗孔、銑削加工。
- Suitable for vertical milling and drilling operations.

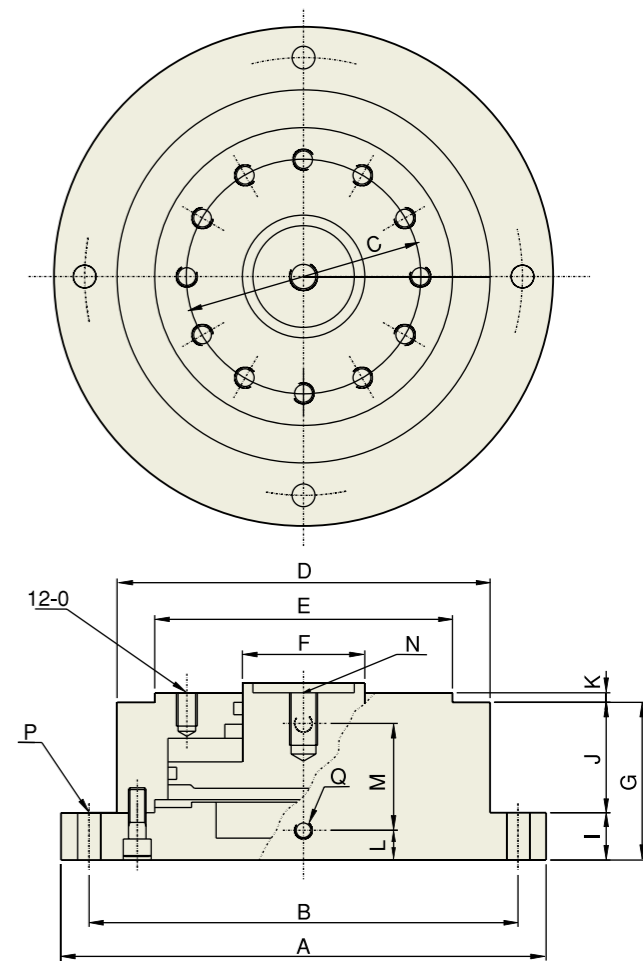

規格 SPECIFICATIONS

型式 Model	尺寸 Dim	活塞直徑 Piston Dia (mm)	活塞面積 Effective Piston Area		活塞行程 Piston Stroke (mm)	最大拉桿推力 Max. Draw Bar Pull		重量 Weight (kg)	最高使用油壓力 Max. Operating pressure (kgf/cm <sup>2</sup> )	適用夾頭 Matching Chuck
			推側 Push Side (cm <sup>2</sup> )	拉側 Pull Side (cm <sup>2</sup> )		推側 Push Side (kgf)	拉側 Pull Side (kgf)			
6" 立式座 DOV		ø115	104	78.5	20	1900	1400	12	20	V206
8" 立式座 DOV		ø155	187	148.6	17	3600	2800	21	20	V208 V210

尺寸表 DIMENSIONS

尺寸 Dim	型式 Model	6" 立式座 DOV	8" 立式座 DOV
A		220	285
B		205	250
C		ø104.8	ø133.4
D		ø168	ø210
E		ø140	ø170
F		ø55	ø70
G		60	80.5
I		16	24

尺寸 Dim	型式 Model	6" 立式座 DOV	8" 立式座 DOV
K		5.5	5.5
L		15	15
M		50	60
N		M14xP2.0	M16xP2.0
O		M12深24	M12深24
P		4-ø13	4-ø13
Q		PT1/4"	PT1/4"

3-JAW WEDGE TYPE NON THROUGH-HOLE WATERPROOF POWER CHUCK (WITH ADAPTOR)

- 防水夾頭適用於立式與臥式CNC車床。
- Waterproof power chuck is suitable for vertical and horizontal CNC lathe.

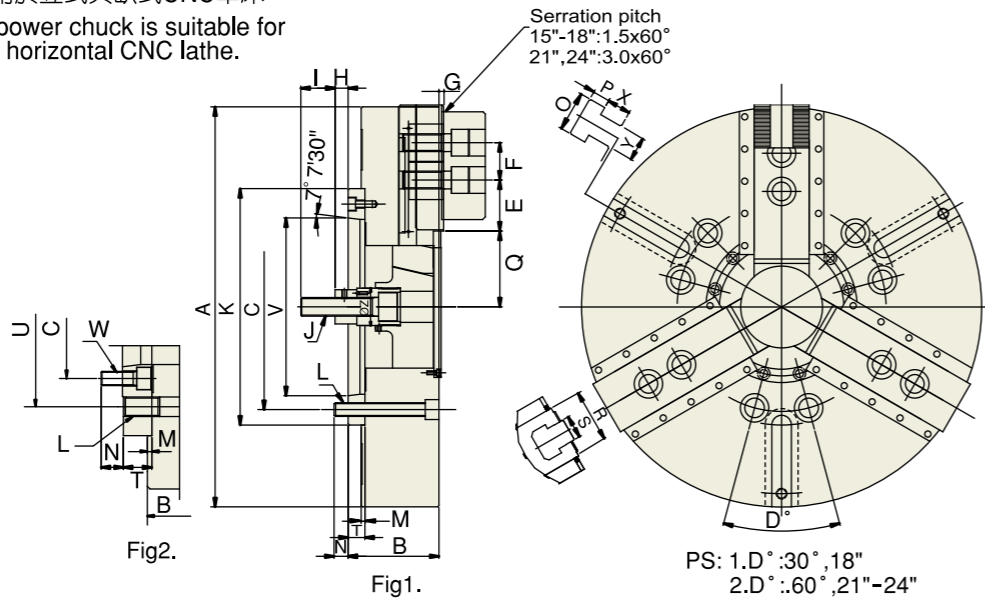

規格 SPECIFICATIONS

尺寸 Dim	型式 model	爪行程(直徑) Jaw Stroke (Dia) (mm)	柱塞行程 Plunger Stroke (mm)	最大推力 Max. Pull Force (kgf)	最大夾持力 / 油壓壓力 Max. Gripping Force (kgf)/ (kgf/cm <sup>2</sup> )	最高轉速 Max. Speed (r.p.m)	重量 Weight (kg)	慣性矩 Moment of Inertia (kgf.m <sup>2</sup> )	適合油壓缸 Matching Cylinder	適合之軟爪 Matching Soft Jaw	適合之硬爪 Matching Hard Jaw
	VW-218A8	16	35	8362	25391/32.6	2700	134	2.41	MS-200	HC-15-1	HJ-15-1
	VW-218A11	16	35	8362	25391/32.6	2700	123	2.11	MS-200	HC-15-1	HJ-15-1
	VW-221A11	16	35	8362	25391/32.6	1900	193	5.1	MS-200	HC-21-1	HJ-21-1
	VW-221A15	16	35	8362	25391/32.6	1900	187	4.9	MS-200	HC-21-1	HJ-21-1
	VW-224A11	16	35	8362	25391/32.6	1750	239	7.5	MS-200	HC-21-1	HJ-21-1
	VW-224A15	16	35	8362	25391/32.6	1750	233	7.1	MS-200	HC-21-1	HJ-21-1

尺寸表 DIMENSIONS

尺寸 Dim	型式 model	VW-218A8	VW-218A11	VW-221A11	VW-221A15	VW-224A11	VW-224A15
A		450	450	530	530	610	610
B		141	130	146	146	146	146
C		171.45	235	235	330.2	235	330.2
F		43	43	60	60	60	60
K		300	300	380	380	380	380
L		6-M16	6-M20	6-M20	6-M24	6-M20	6-M24
M		6	6	6	6	6	6
N		24	22	24	34	28	34
T		33	22	27	27	27	27
V		139.719	196.869	196.869	285.75	196.869	285.75
U		171.45	235	235	330.2	235	330.2
E	Max.	50.25	50.25	93.5	93.5	93.5	93.5
E	Min.	23.25	23.25	24.5	24.5	24.5	24.5
G		3	3	3	3	3	3
H	Max.	71	78	56	56	56	56
H	Min.	36	43	21	21	21	21
I		55	55	55	55	55	55
J		M30X3.5	M30X3.5	M30X3.5	M30X3.5	M30X3.5	M30X3.5
Q	Max.	108	108	86	86	125	125
Q	Min.	100	100	78	78	117	117
R		62	62	62	62	62	62
S		25.5	25.5	25	25	25	25
W		6-M16	-	6-M20	-	6-M20	-
X		16	16	16	16	16	16
Y		22	22	22	22	22	22
P		22	22	22	22	22	22
O		37	37	37	37	37	37
Z		60	60	60	60	60	60
參考圖 Reference		Fig. 2	Fig. 1	Fig. 2	Fig. 1	Fig. 2	Fig. 1

SUPER HIGH SPEED THROUGH-HOLE ROTARY HYDRAULIC CYLINDER



- 內附逆止閥。(With check valve)

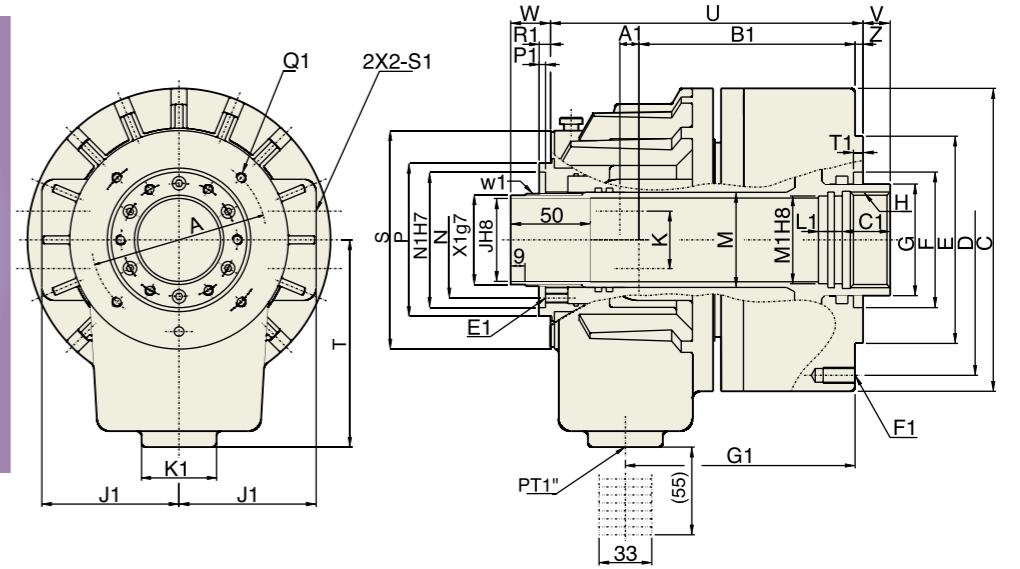

規格 SPECIFICATIONS

代號 Symbol	活塞面積 Effective Piston Area (cm <sup>2</sup> )		活塞行程 Piston stroke (mm)	最高使用迴轉速 Max. speed (r.p.m.)	最高使用壓力 Max. pressure (kgf/cm <sup>2</sup> )	慣性矩 Moment of inertia (kgf.m <sup>2</sup> )	重量 Weight (kg)	回油量 (含內部排油量) Max oil leakage from drain port and max internal oil leakage (lit/min)
	伸側 Extend	引側 Retract						
RC	4	47	41.5	9	8000	0.02	5.6	3
	5	67	64.5	15	8000	0.044	8.6	3
	6	100	89	15	7000	0.078	12	3
	8	161	150	22	6200	0.21	16.8	3.9
	10	198	183	25	4700	0.38	26	4.2
	10X	198	183	25	4700	0.38	26	4.2
	12	252	234	30	3800	0.61	33	4.5
	15	345	336	23	2800	1.21	55	7

尺寸表 DIMENSIONS

代號 Symbol	規格 Series	C	D	E	F	G	H	J 貫通孔徑	K	M	N	P	S	T	U	V		W		Z	A
		max	min	max	min	max	min	max	min	max	min	max	min	max	min	max	min	max	min	max	min
RC	4	115	100	80	65	44	M38X1.5	28	25	35	44	59	90	105	158	9	0	34	25	5	76
	5	135	115	100	65	48	M42X1.5	36	30	44.8	55	73	106	115	175.5	10	-5	40	25	5	88
	6	155	130	100	80	65	M55X2	46	36	52.9	64	85	118	115	184	10	-5	40	25	5	98
	8	190	170	130	85	70	M60X2	52	36	59.6	73	96	137	130	196	17	-5	47	25	5	110
	10	215	190	160	120	95	M85X2	75	36	84.6	98	121	166	160	230	20	-5	50	25	5	155
	10X	215	190	160	120	95	M87X2	78	36	84.6	98	121	166	160	230	20	-5	50	25	5	155
	12	240	215	180	140	110	M100X2	91	36	99.6	108	138	182	185	253	25	-5	55	25	5	165
	15	310	275	230	166	140	M130X2	117.5	36	118	148	178	225	215	267	18	-5	56	33	5	206

代號 Symbol	規格 Series	A1	B1	C1	E1 深度	F1 深度	G1	J1	K1	L1	M1	N1	P1	Q1 深度	R1	S1	T1	W1	X1
		RC	4	9.5	106	25	M6X10	M8X20	114.5	60	47	15	30	53	4	M4X10	5	PT 3/8	6
5	11		120.5	25	M5X9	M10X20	126.5	66	47	15	38	64	4	M5X10	5	PT 3/8	6	M44X1.5	42
6	11.5		126.5	30	M6X9	M10X20	135	76	47	15	50	76	4	M5X10	6	PT 1/2	6	M52X1.5	50
8	12		136	30	M6X9	M10X20	145	86	47	15	55	85	4	M6X12	7	PT 1/2	6	M58X1.5	56
10	17.5		153.5	35	M6X9	M10X20	166.5	101	47	15	80	108	4	M6X12	7	PT 1/2	6	M84X2.0	81
10X	17.5		153.5	35	M6X9	M10X20	166.5	101	47	15	80	108	4	M6X12	7	PT 1/2	6	M84X2.0	81
12	21		168	35	M6X14	M12X24	183	110	47	15	95	120	4	M6X12	7	PT 1/2	6	M99X2	96
15	21		153.5	45	M6X10.5	M16X24	197	129	55	20	123	160	5	M6X12	7	PT 1/2	6	M134X2	131

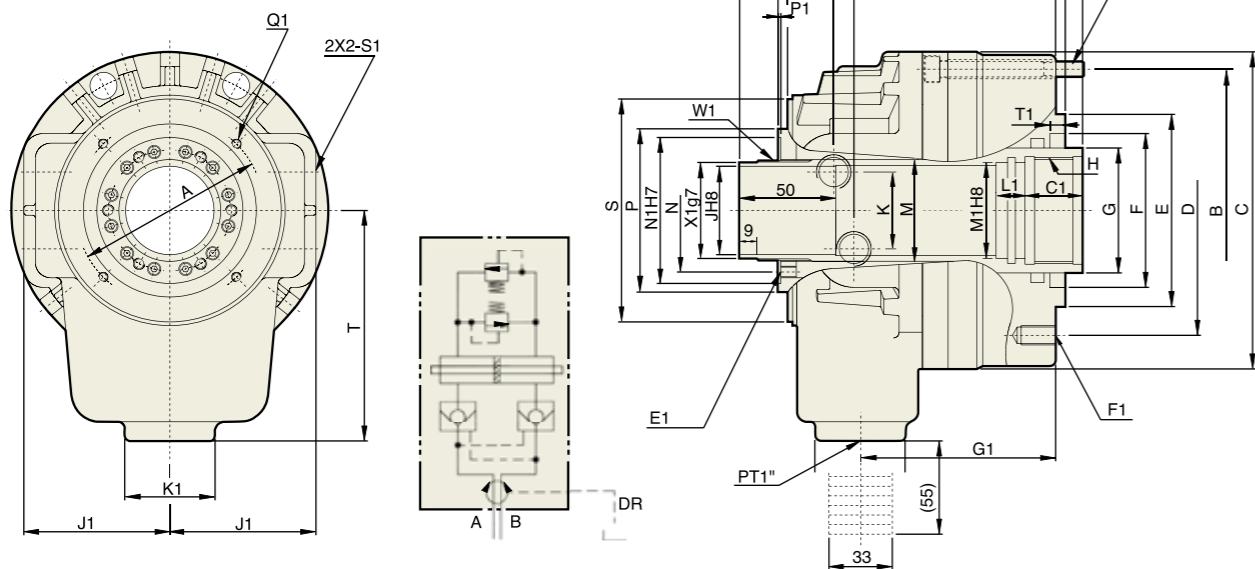

規格 SPECIFICATIONS

代號 Symbol 型式 Model	活塞面積 Effective Piston Area (cm <sup>2</sup> )		活塞行程 Piston stroke (mm)	最高使用 迴轉速 Max. speed (r.p.m)	最高使用 壓力 Max. pressure (kgf/cm <sup>2</sup> )	慣性矩 Moment of inertia (kgf·m <sup>2</sup> )	重量 Weight (kg)	回油量 (含內部排油量) Max oil leakage from drain port and max internal oil leakage (lit/min)
	押側 Extend	引側 Retract						
RCS	6	100	89	15	8000	0.071	9	3
	8	148	138	22	6500			
	10	183	169	25	5500			

尺寸表 DIMENSIONS

代號 Symbol 型式 Model	C	D	E	F	G	H	J 貫通 孔徑	K	M	N	P	S	T	U	V		W		Z	A	B	
	max		min		max		min		max		min		max		min		max		min			
RCS	6	165	130	100	80	65	M55X2.0	46	40	52.9	64	85	116	120	139.5	14	-1	40	25	5	98	147
	8	185	170	130	85	70	M60X2.0	52	40	59.6	73	96	135	130	150.5	21	-1	42	20	5	110	165
	10	215	190	160	120	95	M85X2.0	75	46	84.6	98	121	163	160	169.5	24	-1	50	25	5	155	195

代號 Symbol 型式 Model	A1	B1	C1	E1 深度	F1 深度	G1	J1	K1	L1	M1	N1	P1	Q1 深度	R1	S1	T1	W1	X1	Y	
	RCS	6	10.5	105	30	M6X6	M10X20	101.5	76	47	15	50	76	1.5	M5X6	5	PT <sup>3</sup> / <sub>8</sub>	8	M52X1.5	50
8		11.5	110.5	30	M6X9	M10X20	110.5	86	47	15	55	85	3	M6X7	5	PT <sup>1</sup> / <sub>2</sub>	6	M58X1.5	56	6-M8X80
10		17.5	125.5	35	M6X10	M10X20	126.5	101	47	15	80	108	3	M6X7	7	PT <sup>1</sup> / <sub>2</sub>	6	M84X2.0	81	6-M10X90

1. 超薄型：總長僅為原來 2/3 長。  
• Ultra thin. 2/3 of original length.

2. 內裝逆止閥，安全自鎖機構及壓力卸載閥。  
• Built-in check valve, safety Auto lock and pressure relief valves.

3. 裝配時可由後方上緊固鎖。  
• Assembling from rear side is available.

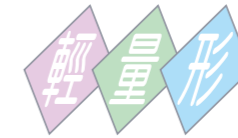

- 採用高級鋁合金製造，體積小重量輕，可減輕機械主軸負擔。
- 高轉速由於體型輕巧，精密度高適合高轉速。
- Compact size and light weight, made of alloy aluminum to lighten loading of spindle.
- Suitable for high speed turning.

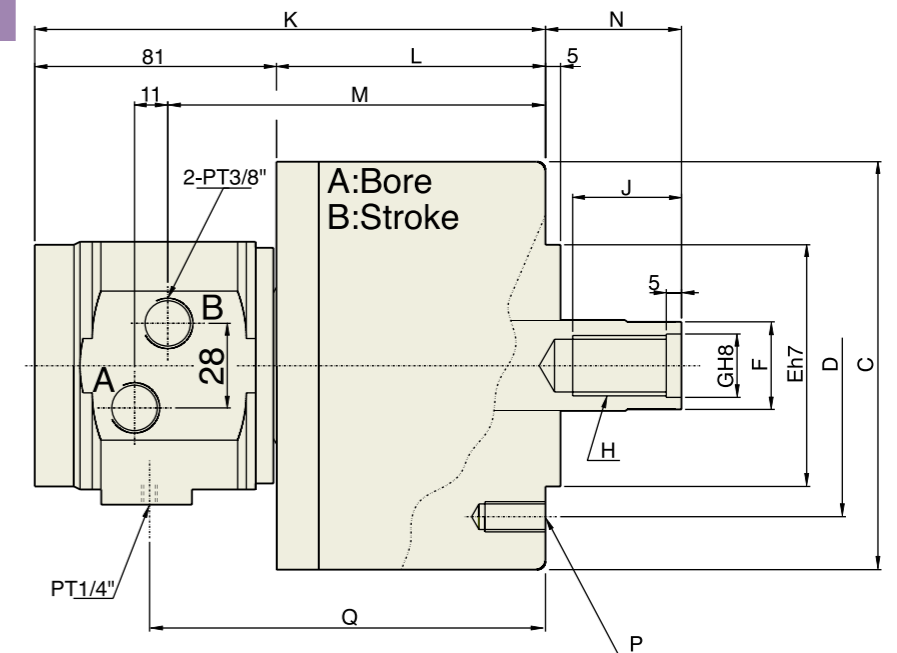
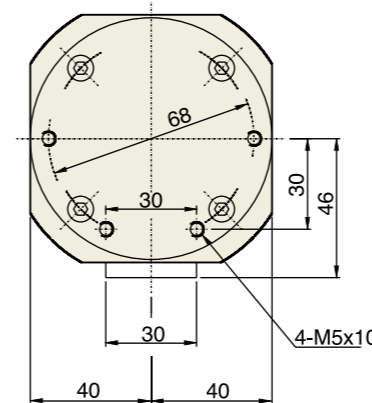

規格 SPECIFICATIONS

型式 MODEL	活塞行程 Piston Stroke (mm)	活塞面積 Piston Area		最大活塞拉力 Max. Draw Bar Pull KN(kgf)	最高使用油壓力 Max. Operating Pressure MPa(kgf/cm <sup>2</sup> )	總洩流量 Total Leakage (l/min)	最高轉速 Max. Speed (r.p.m.)	重量 Weight (kg)	慣性矩 Moment of Inertia N.m (kgf·m <sup>2</sup> )
		推側 Push Side (cm <sup>2</sup> )	拉側 Pull Side (cm <sup>2</sup> )						
MH75	15	44	39	15.5(1560)	4.0(40.8)	0.8	6,000	3.6	0.108(0.011)
MH105	20	86	81	32(3240)	4.0(40.8)	0.8	6,000	6.3	0.39(0.04)
MH125	25	122	115	46(4600)	4.0(40.8)	0.8	6,000	9	0.88(0.09)
MH150	30	176	160	63(6424)	4.0(40.8)	0.8	5,500	12.5	1.86(0.19)
MH200	35	314	290	113(11523)	4.0(40.8)	0.8	5,500	21	3.82(0.39)

尺寸表 DIMENSIONS

型式 MODEL	A	B	C	D	E	F	G	H	J	K	L	M	Nmax.	Nmin.	P	Q
MH75	75	15	104	90	65	30	21	M20X2.5	35	147	66	102	46	31	6-M8X1.25	108
MH105	105	20	135	100	80	30	21	M20X2.5	35	170	89	125	45	25	6-M10X1.5	131
MH125	125	25	160	130	110	35	25	M24X3.0	44	178	97	133	51	26	6-M12X1.75	139
MH150	150	30	190	130	110	45	31	M30X3.5	45	187	106	142	56	26	12-M12X1.75	148
MH200	200	35	245	145	120	55	37	M36X4.0	60	203	122	158	69	34	12-M16X30	164



- 內附逆止閥，當壓力源故障時或油壓配管受損停電等供給壓力異常下降時之壓力保持，免除工作飛出之危險。
- Whenever the hydraulic pressure is depressing (for example: main power shut down,damage of the hydraulic pipe..ect. The check valve will remain the pressure for preventing any damage by accident.

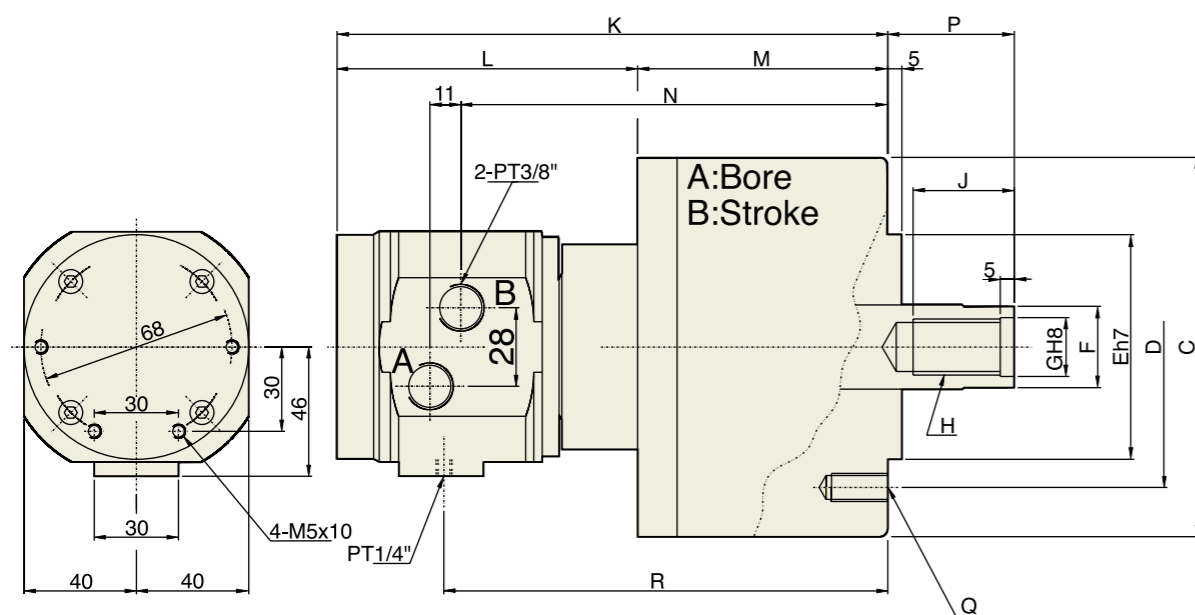

規格 SPECIFICATIONS

型式 MODEL	活塞行程 Piston Stroke (mm)	活塞面積 Effective Piston Area		最大拉桿推力 Max.Draw Bar Pull <拉側 Pull side> KN(kgf)	最高使用油壓力 Max.Operating Pressure MPa (kgf/cm <sup>2</sup> )	總流量 Total Leakage (l/min)	最高轉速 Max. Speed (r.p.m.)	重量 Weight (kg)	慣性矩 Moment of Inertia (kgf.m <sup>2</sup> )
		推側 Push Side (cm <sup>2</sup> )	拉側 Pull Side (cm <sup>2</sup> )						
MS105	20	86	79	29(2957)	4.0(40.8)	0.8	6,000	7.1	0.0125
MS125	25	122	113	42(4283)	4.0(40.8)	0.8	6,000	10	0.0225
MS150	30	176	160	60(6118)	4.0(40.8)	0.8	5,500	13.5	0.0475
MS200	35	314	290	108(11013)	4.0(40.8)	0.8	5,500	22	0.0975

尺寸表 DIMENSIONS

型式 MODEL	A	B	C	D	E	F	G	H	J	K	L	M	N	P Max.	P Min.	Q	R
MS105	105	20	135	100	80	30	21	M20X2.5	35	197	108	89	152	45	25	6- M10X20	158
MS125	125	25	160	130	110	35	25	M24X3.0	44	205	108	97	160	51	26	6- M12X24	166
MS150	150	30	190	130	110	45	31	M30X3.5	45	214	108	106	169	56	26	12- M12X24	175
MS200	200	35	245	145	120	55	37	M36X4.0	60	228	106	122	183	69	34	12- M16X30	189

- 拉桿推力：油壓力 4.0MPa(40.8 kg/cm<sup>2</sup>)
- Draw bar pull force:Pressure 4.0MPa(40.8 kg/cm<sup>2</sup>)
- 總流量：油壓力 3.0MPa(30.6 kg/cm<sup>2</sup>) 及溫度50 °C
- Total leakage :Pressure 3.0MPa(30.6 kg/cm<sup>2</sup>)and oil temperature 50 °C



- 內附逆止閥。
- 檢知確認裝置。
- Built-in safety check valves.

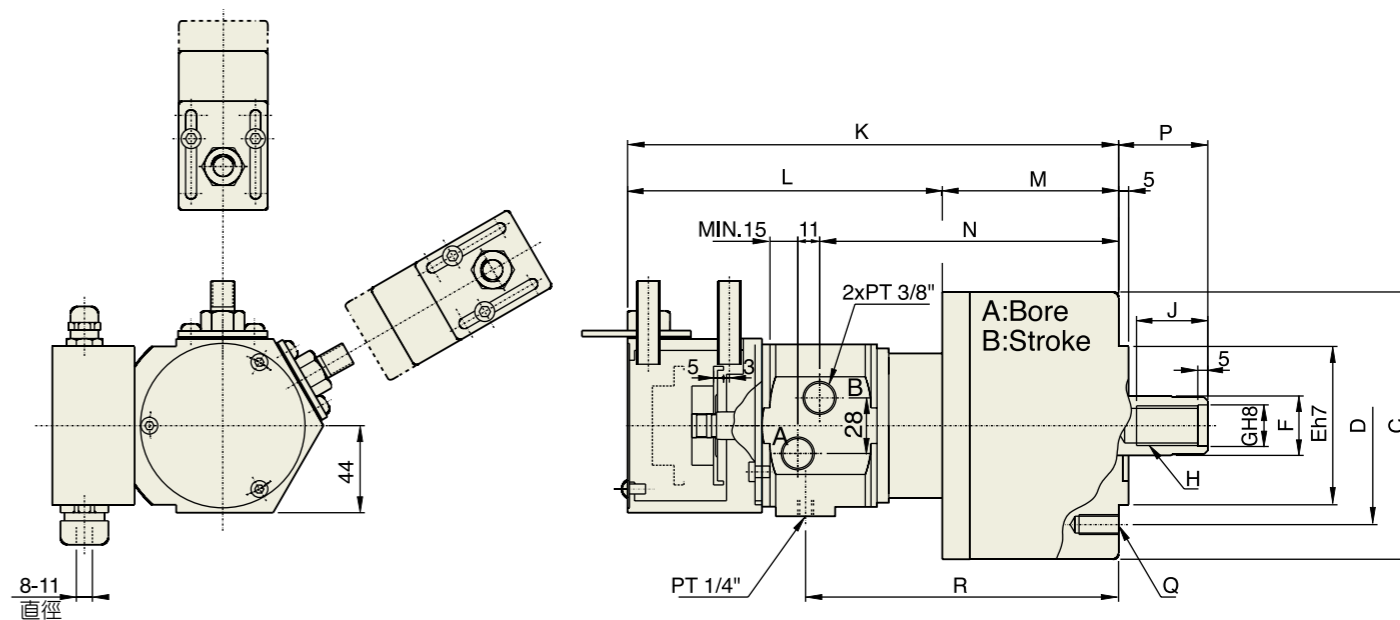

規格 SPECIFICATIONS

型式 MODEL	活塞行程 Piston Stroke (mm)	活塞面積 Effective Piston Area		最大拉桿推力 Max.Draw Bar Pull <拉側 Pull side> KN(kgf)	最高使用油壓力 Max. Operating Pressure MPa <拉側 Pull side> (kgf/cm <sup>2</sup> )	總流量 Total Leakage (l/min)	最高轉速 Max. Speed (r.p.m.)	重量 Weight (kg)	慣性矩 Moment of Inertia (kgf.m <sup>2</sup> )
		推側 Push Side (cm <sup>2</sup> )	拉側 Pull Side (cm <sup>2</sup> )						
MS105C	20	84	79	29(2957)	4.0(40.8)	0.8	6,000	7.6	0.0125
MS125C	25	120	113	42(4283)	4.0(40.8)	0.8	6,000	10.5	0.022
MS150C	30	174	160	60(6118)	4.0(40.8)	0.8	5,500	14	0.047
MS200C	35	312	290	108(11013)	4.0(40.8)	0.8	5,500	22.5	0.097

尺寸表 DIMENSIONS

型式 MODEL	A	B	C	D	E	F	G	H	J	K	L	M	N	P Max	P Min	Q	R	S	T
MS105C	105	20	135	100	80	30	21	M20X2.5	35	252	163	89	152	45	25	6-M10X20	158	23	41
MS125C	125	25	160	130	110	35	25	M24X3.0	44	260	163	97	160	51	26	6-M12X24	166	23	41
MS150C	150	30	190	130	110	45	31	M30X3.5	45	269	163	106	169	56	26	12-M12X24	175	23	41
MS200C	200	35	245	145	120	55	37	M36X4.0	60	288	166	122	185	69	34	12-M16X30	189	28	46

- 拉桿推力：油壓力 4.0MPa(40.8 kg/cm<sup>2</sup>)
- Draw bar pull force:Pressure 4.0MPa(40.8 kg/cm<sup>2</sup>)
- 總流量：油壓力 3.0MPa(30.6 kg/cm<sup>2</sup>) 及溫度50 °C
- Total leakage :Pressure 3.0MPa(30.6 kg/cm<sup>2</sup>)and oil temperature 50 °C
- 近接開關：規格 BES516-329-E4-Y(BALLUFF) DC 12/24V 200mA NPN
- Proximity switch:Model BES516-329-E4-Y9BALLUFF) DC12/24V 200mA NPN

**HYDRAULIC CYLINDER COOLANT COLLECTOR**

**CM-B SERIES**

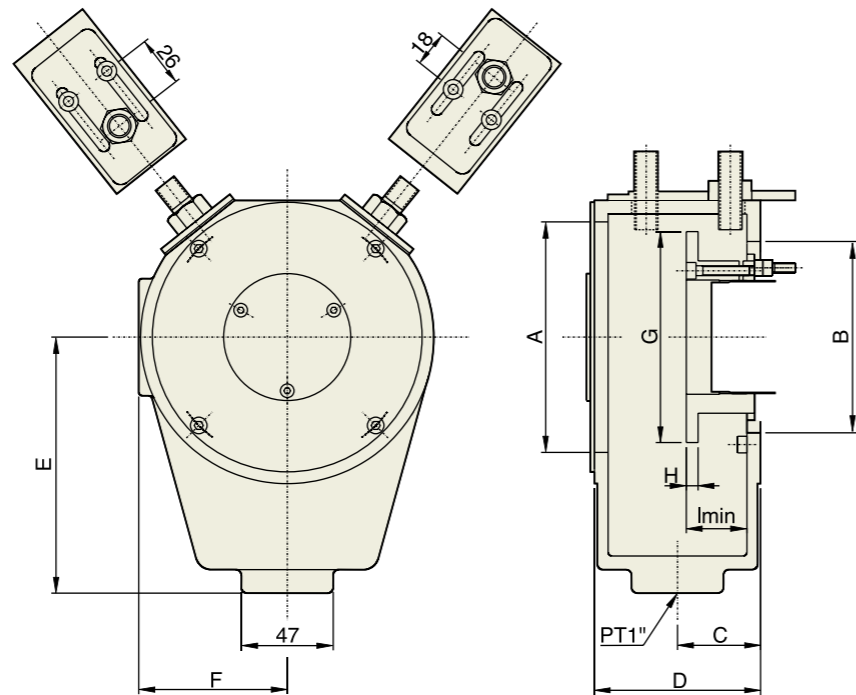
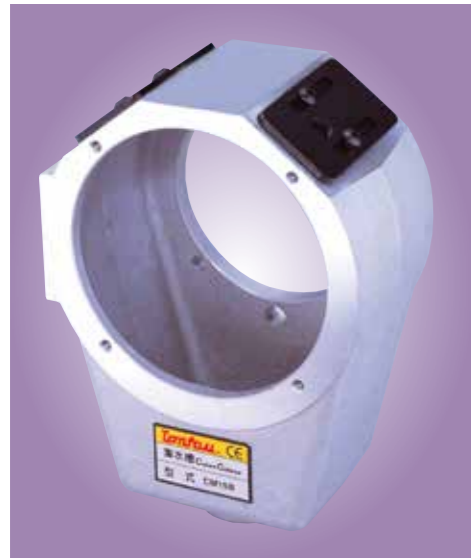

- 可安裝行程確認裝置及油水回收。
- Hydraulic cylinder coolant collector. Compact and light weight, the feature is the bore size up to 20% larger than conventional cylinders. Precision finished piston bores and cool running rotary unions have trouble-free performance for years.

**尺寸表 DIMENSIONS**

型式 Model	尺寸 DIM	A	B	C	D	E	F	G	H	Imin	適合油壓缸 Matching cylinder
CM08B		78	61	42	84	115	60.5	90	6	22	RC-4
CM10B		78	75	42	84	115	60.5	90	6	22	RC-5
CM12B		118	87	42	88.5	131	76	107	6	23	RC-6
CM15B		158	98	44	88.5	151	96	147	6	23	RC-8
CM18B		158	123	44	88.5	151	96	147	6	23	RC-10
CM20B		158	140	44	88.5	151	96	147	6	22.5	RC-12
CM25B		198	180	44	105	215	126	200	6	25	RC-15

**STANDARD HARD JAW**

**HJ SERIES**

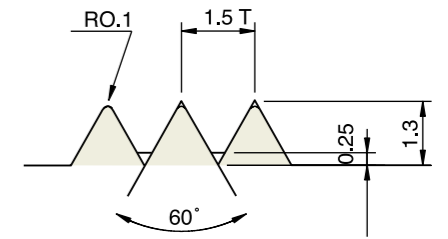

排齒詳圖  
Drawing of Serration

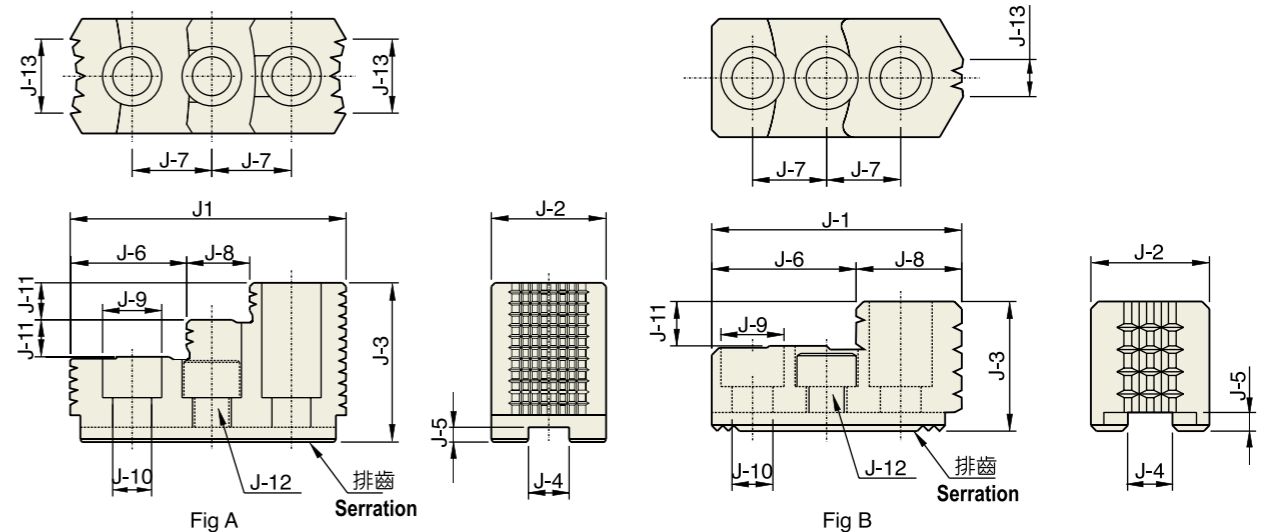

**尺寸表 DIMENSIONS**

型式 Model	J-1	J-2	J-3	J-4	J-5	J-6	J-7	J-8	J-9	J-10	J-11	J-12	J-13	排齒節距 Serration	參考圖 Reference
HJ05	53	23	27.5	10	4	30.5	14	25.5	13.5	8.5	10	M8	6	1.5X60°	B
HJ06	67.5	32	35	12	5	39	20	28.5	17	11	12	M10	10	1.5X60°	B
HJ08	86	35	51	14	5	31	25	18	19	13	12	M12	12	1.5X60°	A
HJ10	99.5	40	54	16	5	43	30	17	19	13	13	M12	15	1.5X60°	A
HJ12	103	50	52	21	5	62.5	30	40.5	25	17	17	M16	30	1.5X60°	B
HJ12-1	103	50	52	18	5	62.5	30	40.5	22	15	17	M14	30	1.5X60°	
HJ15	149	62	86	22	8	63	43	34	32	21	20	M20	40	1.5X60°	A
HJ15-1	149	62	86	25.5	5	63	43	34	32	21	20	M20	40	1.5X60°	
HJ-21	165	65	90	25	9	104.5	50	55	32	21	40	M20	55	3.0x60°	B

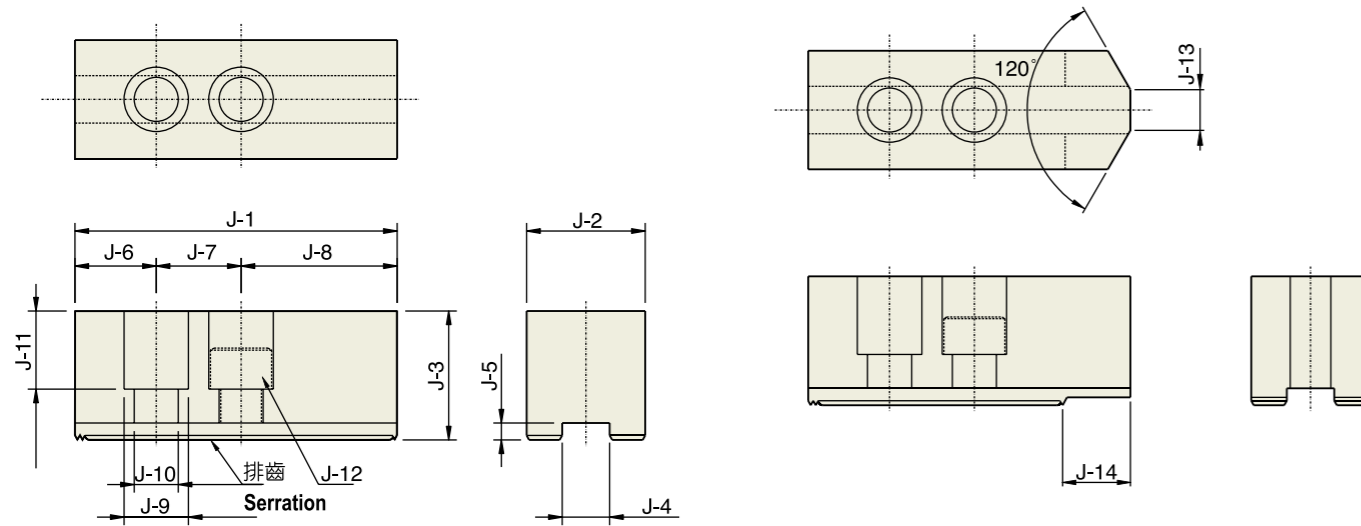
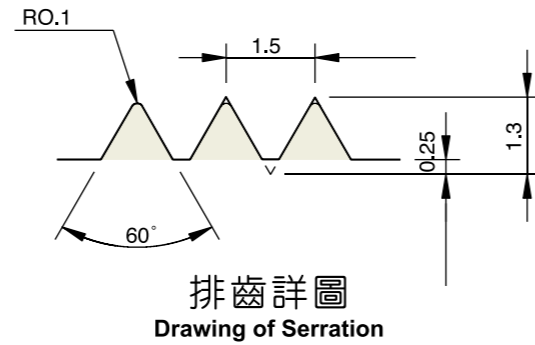

■ 尺寸表 DIMENSIONS

型 式 Model	J-1	J-2	J-3	J-4	J-5	J-6	J-7	J-8	J-9	J-10	J-11	J-12	J-13	J-14	排齒節距 Serration
HC04	49.5	23	23	10	4	10	14	25.5	13.5	8.5	14	M8	4		1.5X60°
HC05	54	23	25	10	4	12	14	28	13.5	8.5	16	M8	5		1.5X60°
HC06	66	32	28	12	5	12	20	34	17	11	16	M10	5	12	1.5X60°
HC08	95	35	38	14	5	24	25	46	19	13	23	M12	12	20	1.5X60°
HC10	110	40	42	16	6	30	30	50	19	13	27	M12	18	20	1.5X60°
HC12	130	50	50	21	6	39	30	60	25	17	30	M16	18	30	1.5X60°
HC12-1	130	50	50	18	6	39	30	60	23	15	30	M14	18	30	1.5X60°
HC15	165	62	62	22	8	37	43	85	32	21	38	M20			1.5X60°
HC15-1	135	50	60	25.5	5	26	43	66	32	21	39	M20	-	-	1.5X60°
HC-21	185	62	70	25	9	40	60	85	32	21	46	M20	-	-	3.0X60°

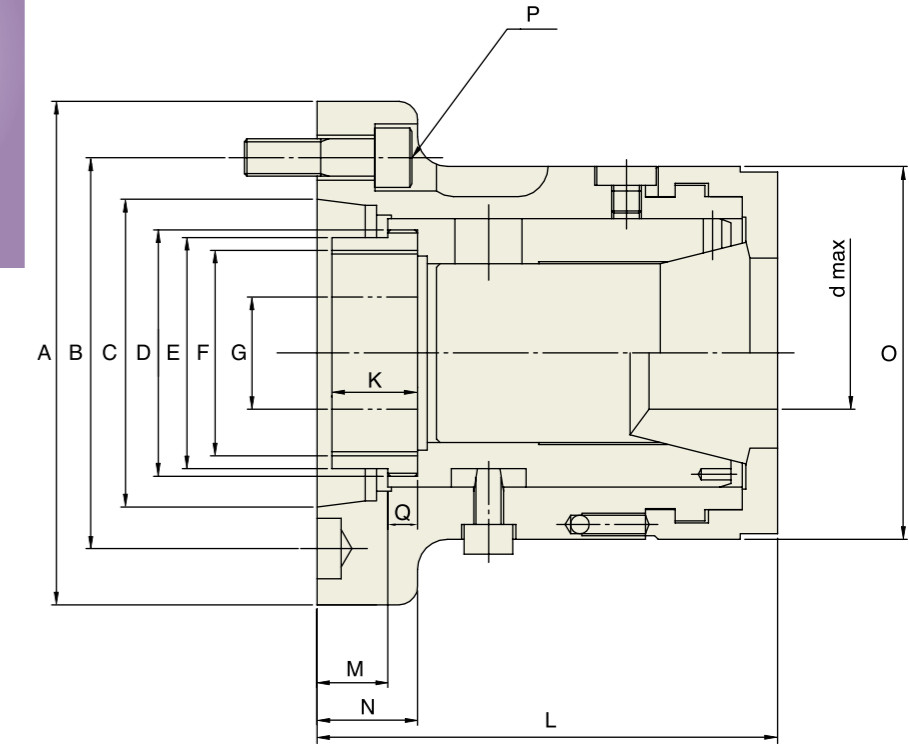

■ 尺寸表 DIMENSIONS

規格 Model	CL30-A4	CL36-A5	CL42-A5	CL42-A6	CL52-A5	CL52-A6	CL60-A6	CL60-A8	CL80-A8
Max.Speed	7000	6000	6000	6000	6000	6000	5000	5000	4000
Steel Collet	163E	171E	173E	173E	177E	177E	185E	185E	193E
A	112	135	135	170	135	170	170	220	220
B	82.6	104.8	104.8	133.4	104.8	133.4	133.4	171.4	171.4
C	63.5	82.56	82.56	106.36	82.56	106.36	106.36	139.7	139.7
D	M50xP1.5	M66xP1.5	M66xP1.5	M66xP1.5	M70xP1.5	M90xP1.5	M90xP1.5	M90xP1.5	M114xP2.0
E	45	62	62	66	62	66	66	90	108
F	M40xP1.5	M55xP2.0	M55xP2.0	M60xP2.0	M55xP2.0	M60xP2.0	M60xP2.0	M85xP2.0	M100xP2.0
G	20	30	30	30	30	30	30	30	30
K	23	23	23	23	23	31	31	31	31
M max	21.5	26	26	29	26	33	33	33	34
M min	16.5	21	21	24	21	28	28	28	29
N	30	27	27	32	27	27	27	37	35
d	30	36	42	42	52	52	60	60	80
O	87	103	103	103	113	132	132	132	155
L	110	129	129	133	129	155	155	155	175
P	3-M10x30	4-M10x30	4-M10x30	4-M12x30	4-M10x30	4-M12x30	4-M12x30	4-M16x35	6-M16x35
Q	8	8	8	8	8	8	8	8	11

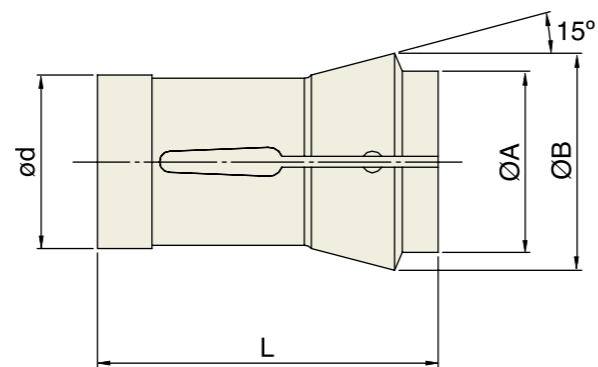
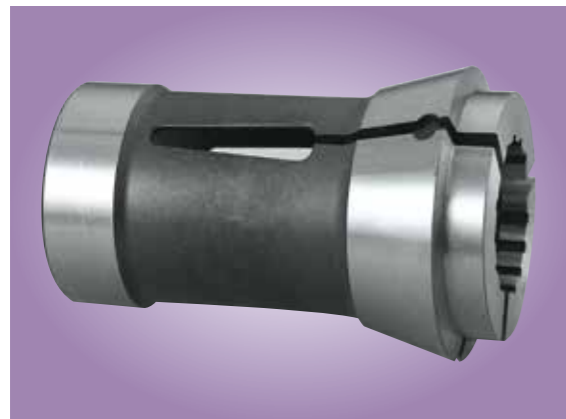

■ 尺寸表 DIMENSIONS

規格 Model	尺寸 Dim	A	B	d	L	Max Dia		
						○	◇	□
163E		39	49	35	80	30	27	22
171E		42	55	42	94	37	32	26
173E		50	60	48	94	42	36	28
177E		60	70	58	94	52	45	36
185E		73	84	66	110	60	50	40
193E		92	107	90	130	80		

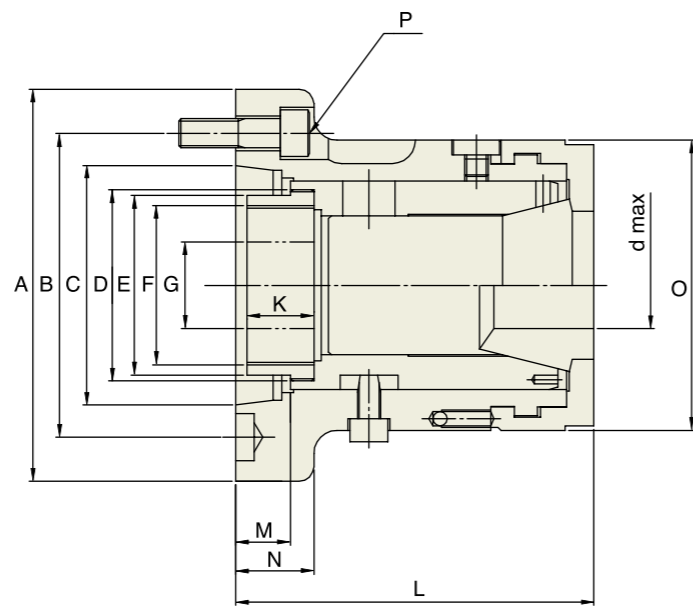

■ 尺寸表 DIMENSIONS

規格 Model	尺寸 Dim	Steel Collet	A	B	C	D	E	F	G	K	L	M max	M min	d max	O	N	P

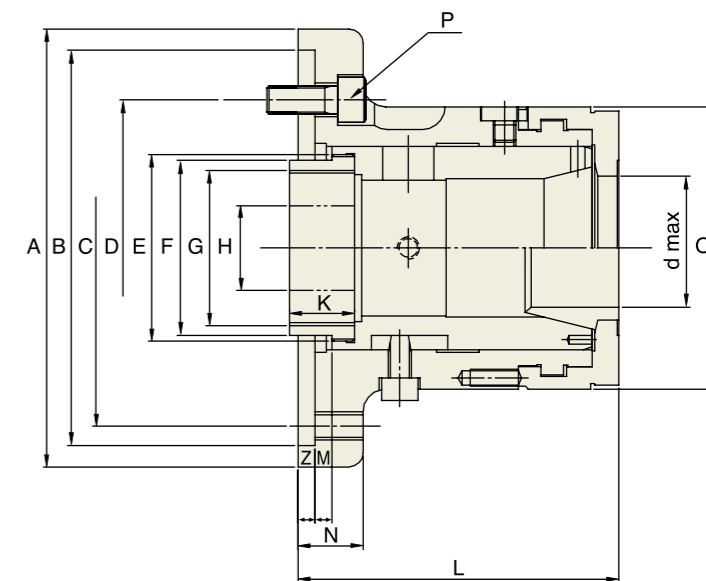

■ 尺寸表 DIMENSIONS

規格 Model	尺寸 Dim	Steel Collet	A	B	C	D	E	F	G	H	K	L	M max	M min	d max	O	N	P	Z
<b>CL42-140D</b>	173E	155	140	126	104.8	M66xP1.5	62	M55xP2.0	30	23	113.5	5	0	42	103	23	4-M10x25	6	
<b>CL52-170D</b>	177E	185	170	152	133.4	M90xP1.5	90	M85xP2.0	30	31	139	11	6	52	132	30	4-M12x25	6	
<b>CL60-170D</b>	185E	185	170	152	133.4	M90xP1.5	90	M85xP2.0	30	31	139	11	6	60	132	30	4-M12x25	6	